



suspension

Incredibly light and easy to dismantle, Hope revives the magic of traditional chandeliers, reinterpreted with sophisticated modern technologies and contemporary materials. A series of thin polycarbonate Fresnel lenses multiply the light, creating a pleasant, sparkling and festive atmosphere, sprinkled with thousands of tiny reflections.

2009

h 49, 54, 66, 90 cm
Ø 61, 72, 110, 200 cm

pressed and bent mirror
polished stainless steel frame

injection moulded
polycarbonate arms

transparent polycarbonate
prismatic lenses

max 250W E27
105/140W halogen energy saver
23W, 42W fluorescent

Leggerissima e scomponibile, Hope ripropone la magia dei lampadari della tradizione, interpretandola con sofisticate tecnologie moderne e materiali contemporanei. Una serie di sottili lenti Fresnel di policarbonato moltiplica la luce della sorgente luminosa, ricreando un gradevole effetto sfavillante, festoso, punteggiato da tanti piccoli riflessi.

Superleicht und zerlegbar: Hope nimmt Bezug auf traditionelle Lampenformen, interpretiert diese aber neu, mit hoch entwickelten neuen Technologien und zeitgemäßen Materialien. Eine Reihe dünner Fresnel-Linsen aus Polycarbonat vervielfacht das Licht des Leuchtmittels und schafft einen angenehmen glitzernden, festlichen, mit zahlreichen kleinen Reflexen blitzenden Effekt.

D'une grande légèreté et démontable à loisir, Hope invite à redécouvrir la magie des lampadaires traditionnels réinterprétée avec les technologies sophistiquées d'aujourd'hui et des matières contemporaines. Une série de fines lentilles de Fresnel en polycarbonate multiplie la lumière de la source lumineuse, recréant ainsi un agréable effet étincelant, festif, ponctué d'une multitude de petits reflets.

Hope, muy ligera y desmontable, propone de nuevo la magia de los candelabros de techo tradicionales, interpretándola con sofisticadas tecnologías modernas y materiales contemporáneos. Una serie de lentes finas de Fresnel en policarbonato multiplica la luz de la fuente luminosa, recreando un agradable efecto resplandeciente, alegre, punteado con muchos pequeños reflejos.



D66/12
weight 1,5 kg

D66/18
weight 2,2 kg

D66/18 EL D
weight 2,6 kg

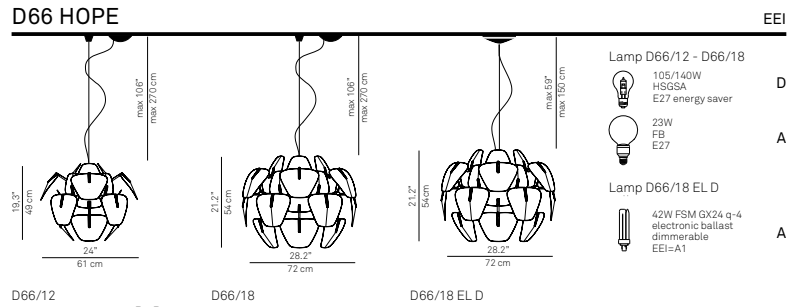

D66/42
weight 7,0 kg

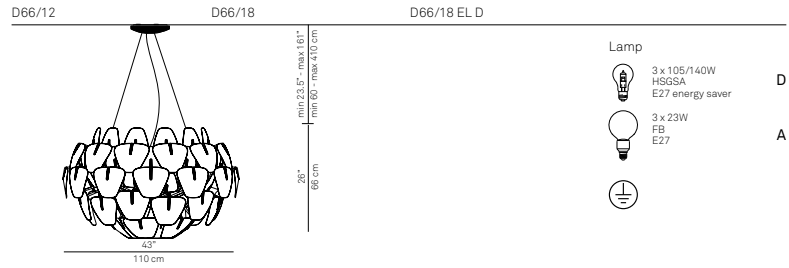

D66/105
weight 18,7 kg

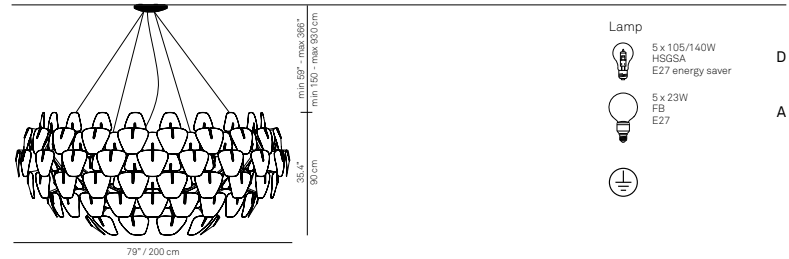

Materials

structure in polished stainless steel and transparent polycarbonate arms, transparent polycarbonate prismatic lenses

Structure finishes

polished and transparent

Lens finishes

transparent

Insulation class



Note

D66/18 EL D version may require functional earthing

for photometric data see www.luceplan.com

D66/8 td.
D66/18 td.

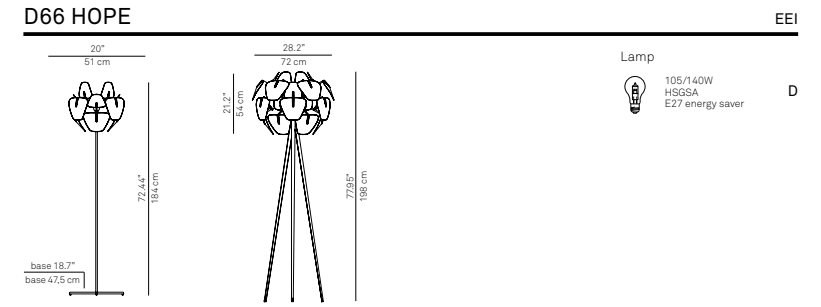

D66/12 p.
weight 2,30 kg

D66/30 p.
weight 4,9 kg

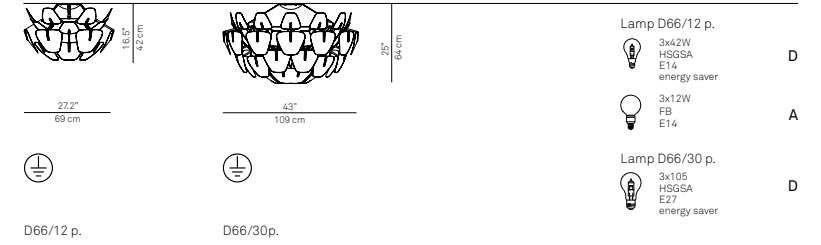

D66/3 a.
weight 2,0 kg

D66/8 a.
weight 2,0 kg

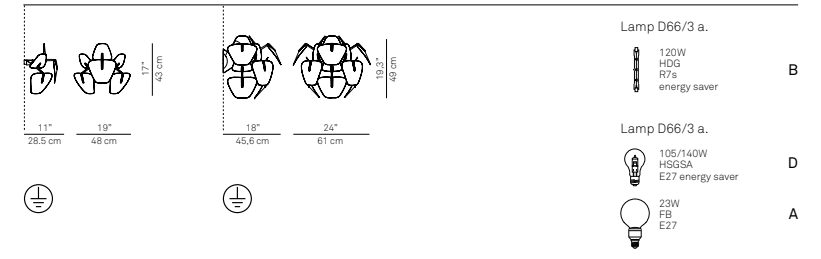

Materials

structure in polished stainless steel and transparent polycarbonate arms, transparent polycarbonate prismatic lenses

Structure finishes

polished and transparent

Lens finishes

transparent

Insulation class



for photometric data see www.luceplan.com